



ITIPACK SYSTEMS OVERVIEW BEVERAGE INDUSTRY

06/07/2023

AGENDA

- ABOUT ITIPACK SYSTEMS
- CORE VALUES
- MISSION
- OUR CAPABILITIES
- OUR HISTORY
- LOCATIONS
- GLASS, CAN, PET MACHINES
- PARTS AND SERVICES
- CONTACTS



ABOUT ITIPACK SYSTEMS

**GREAT PEOPLE. SAFE ENVIRONMENT.
EXCEPTIONAL SERVICE.**

Itipack Systems is a world leader in integrated strapping solutions. Each one of our systems shares in our firm commitment to high value, optimum performance and long-lasting results. The company was founded to provide advanced, custom solutions to industries with specific and unique manufacturing requirements.



WHY ITIPACK

DRIVEN TO INNOVATE

01

Complex Problem Solving

Our success comes from qualified and skilled engineers who can develop concepts that fully address the complete scope of work.

02

Responsive Service

We provide our clients with the best preventative maintenance service and support available within their industry.

03

Creating Efficiency

Our design teams work with you to fully understand your complete process and create tailor-fit solutions that result in faster cycle time, greater uptime, and predictable maintenance.

04

Safe Work Environment

Safety is the number one priority for Itipack and our customers. We build applications that keep everyone working safely. They save lives.



CORE VALUES

Integrity

We will seek to do what is right in all we do, no matter what

Continuous Improvement

We are dedicated to continually improving ourselves, our people and the products we sell

Drive

Driven and motivated to take on any challenges

Commitment

We do what we say we are going to do

Enjoyment

We want our people, our customers and supplier to experience happiness

**“Reduce downtime & increase safety
through quality, custom systems, and
unparalleled service”**

- Our mission



COMPLETELY CAPABLE

Itipack has the capability to produce everything from industry standards to impossible. We deliver results that make everyone proud.



01 INNOVATIVE ENGINEERING

Whether through consulting and sales, or development and engineering, Itipack works closely with customers to provide solution-focused results. There is no one-size-fits-all, quick fix in the strapping industry.

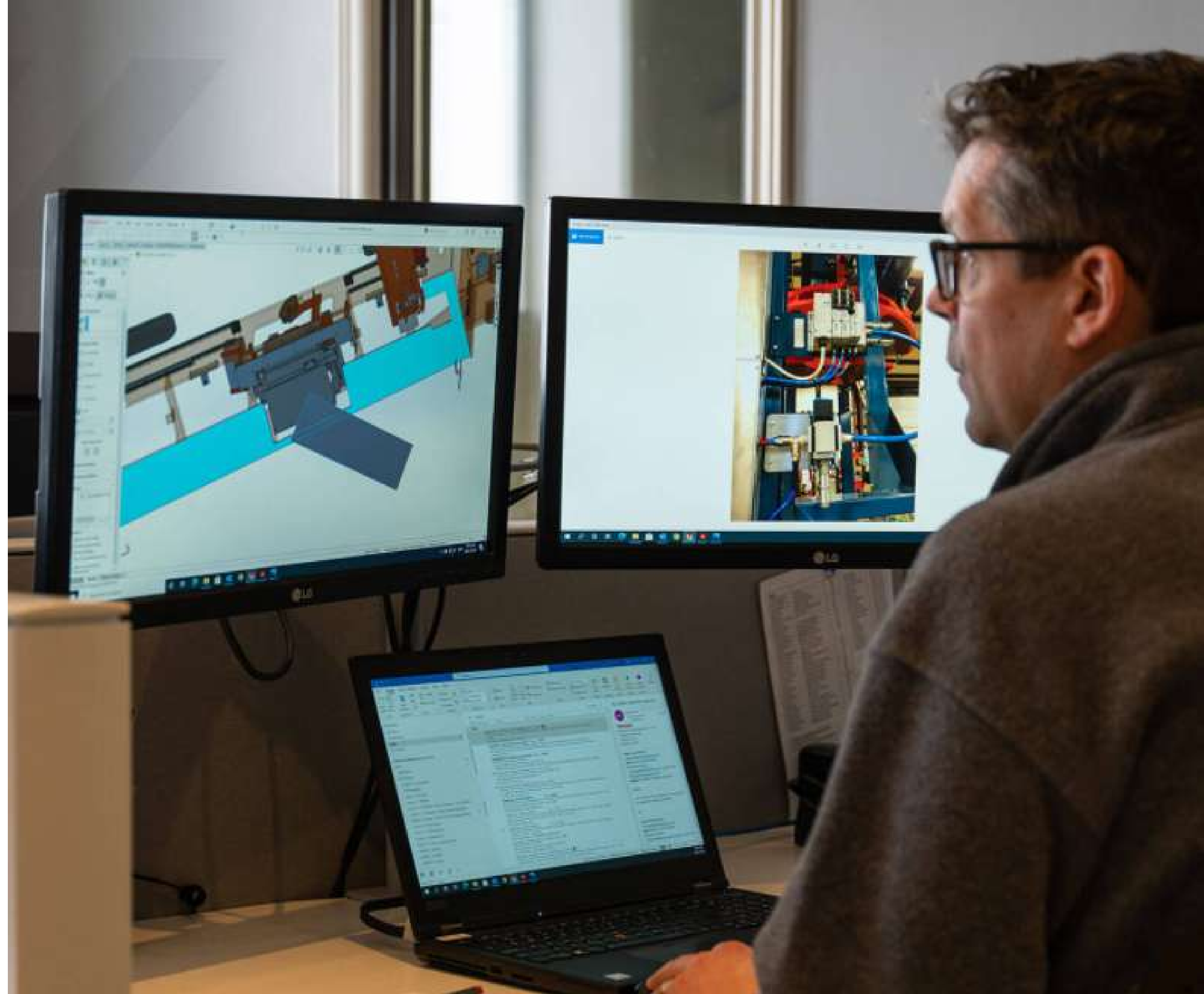



02 **IN-HOUSE PRODUCTION**

Itipack effectively engineers, assembles, integrates, and commissions all of our own equipment. We are proudly owned and operated in North America.

03 RESPONSIVE SERVICE

We are adept at retrofitting older, existing equipment, and commit to servicing it, adding years to the life of the machine. Our parts and service team increases efficiency and reduces costly down time.





OUR HISTORY

1970

Mr. Bruno Benetti incorporates
Itipack SRL.

2001 - 2009

Itipack SRL and A&H Custom Machines partner to
create Itipack Systems North America in
Burlington, Ontario. The parts and service
department is created to answer customer
questions and provide part order fulfillment.





OUR HISTORY

2012 - 2016

On November 12, 2012, the Burlington facility caught fire. All manufacturing moved temporarily. On November 13, 2013, Itipack Systems North America moves back into the rebuilt facility with new manufacturing machines. Itipack Systems North America transforms into Itipack Systems a Division of A&H Custom Machine.



2021

Itipack Systems reveals a new look and integrates HubSpot CRM and Marketing Software for outstanding customer relationships.



LOCATIONS

COME VISIT US



SAN JUAN DE LOS LAGOS
3980 A MONTERREY, N.L,
MEXICO

919 ZELCO DRIVE,
BURLINGTON ON
L7L 4Y2, CANADA

VIA CAPOVILLA, 73, 36030
VILLAVERLA VI, ITALY

Service available our of:

Montreal, Burlington, Chicago,
Charlotte and Monterrey Mexico

GENERAL SOLUTIONS

VKE/MRLPS-2T

Compression	Top 2500KG – 5500lb max Regulation by pressure value min – med. - high
Head	ITP16T – VK10 ITP80TH –K8000
Strap	PET/PP 9-16 mm 0.35 – 5/8 inches
Equipment	Four Columns Version Doble lances Movable up/down lances Small gates for self positioning function Index machine Chain turning table



VERSION 2019

VKE/MRLPS-2T

Compression	Top 2000KG - 5000lb max Regulation by pressure value min - med. - high
Head	ITP16T - VK10 ITP80TH -K8000
Strap	PET/PP 9-16 mm 0.35 - 5/8 inches
Equipment	<u>Two columns version</u> Doble lances Small gates for self positioning function Index machine Chain turning table

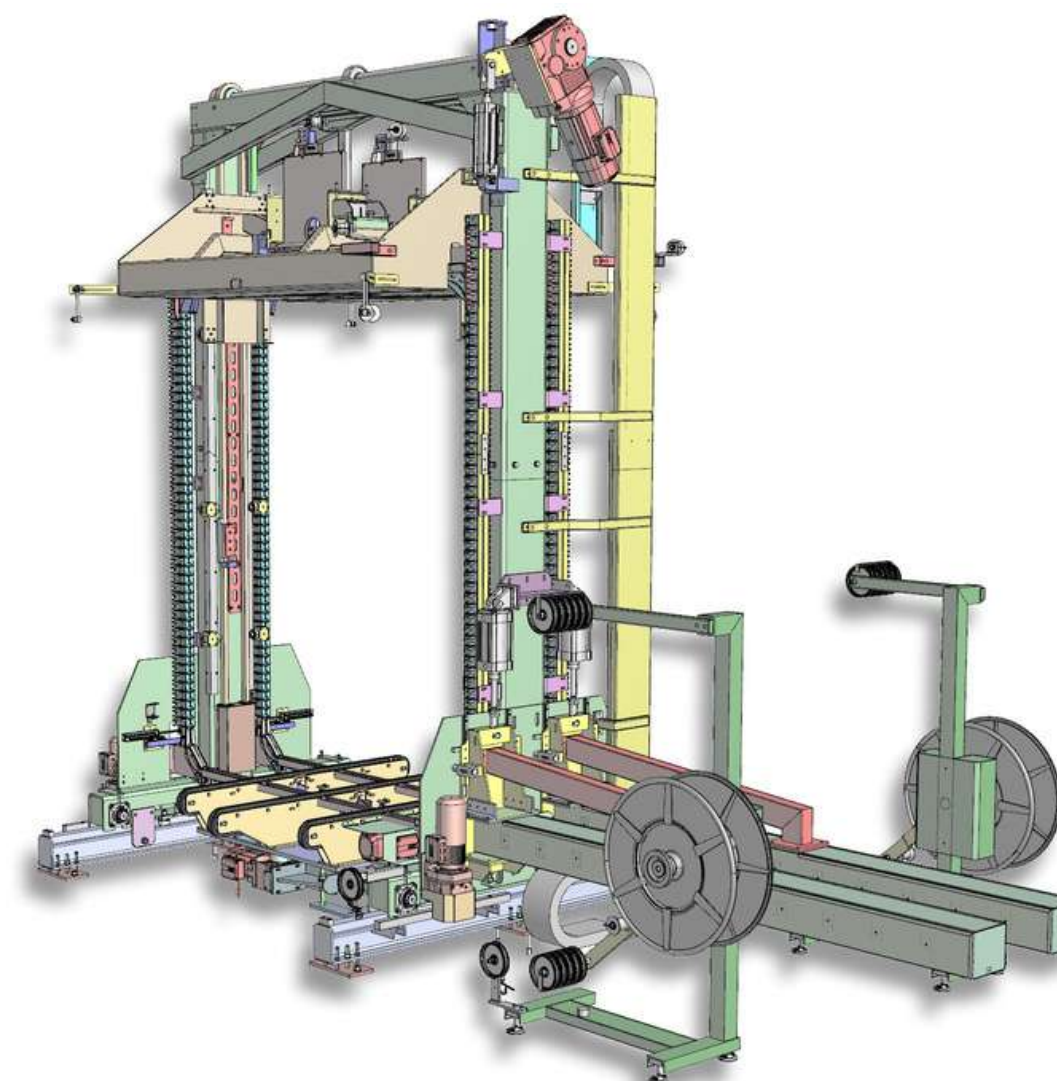

VERSION 2020

VKE/MRLPS-2T

Compression	Top 2000KG – 5000lb max Regulation by pressure value min – med. - high
Head	ITP16T – VK10 ITP80TH -K8000
Strap	PET/PP 9-16 mm 0.35 – 5/8 inches
Equipment	<u>Two columns version</u> Doble lances Small gates for self positioning function Index machine Chain turning table

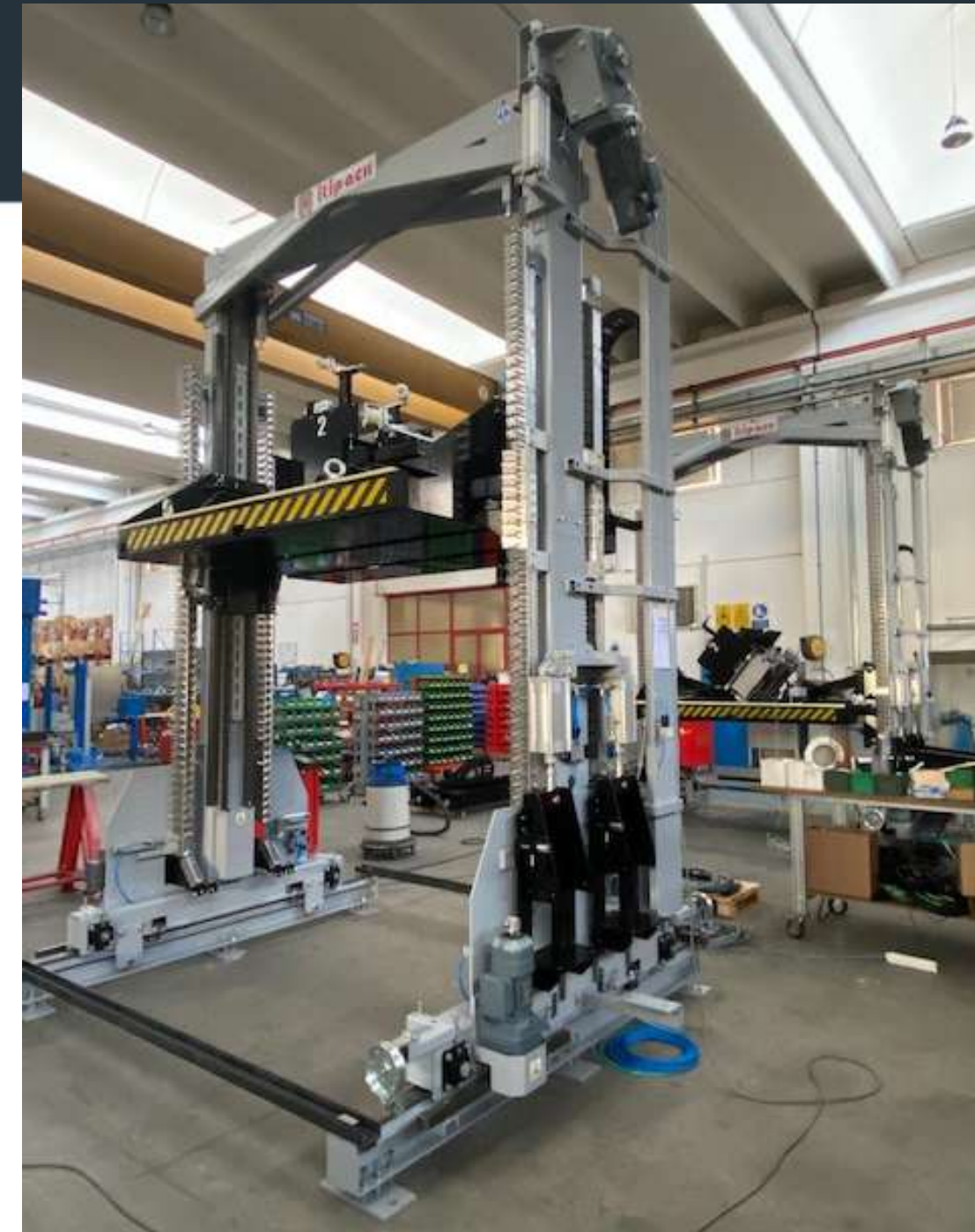

GENERAL SOLUTIONS

VHP/FLS-2T

Compression	Top 2500KG - 5500lb max Regulation by pressure value min - med. - high
Head	ITP16T - VK10 ITP80TH -K8000
Strap	PET/PP 9-16 mm 0.35 - 5/8 inches
Equipment	Two Columns Version Doble lances Small gates for self positioning function Fix machine

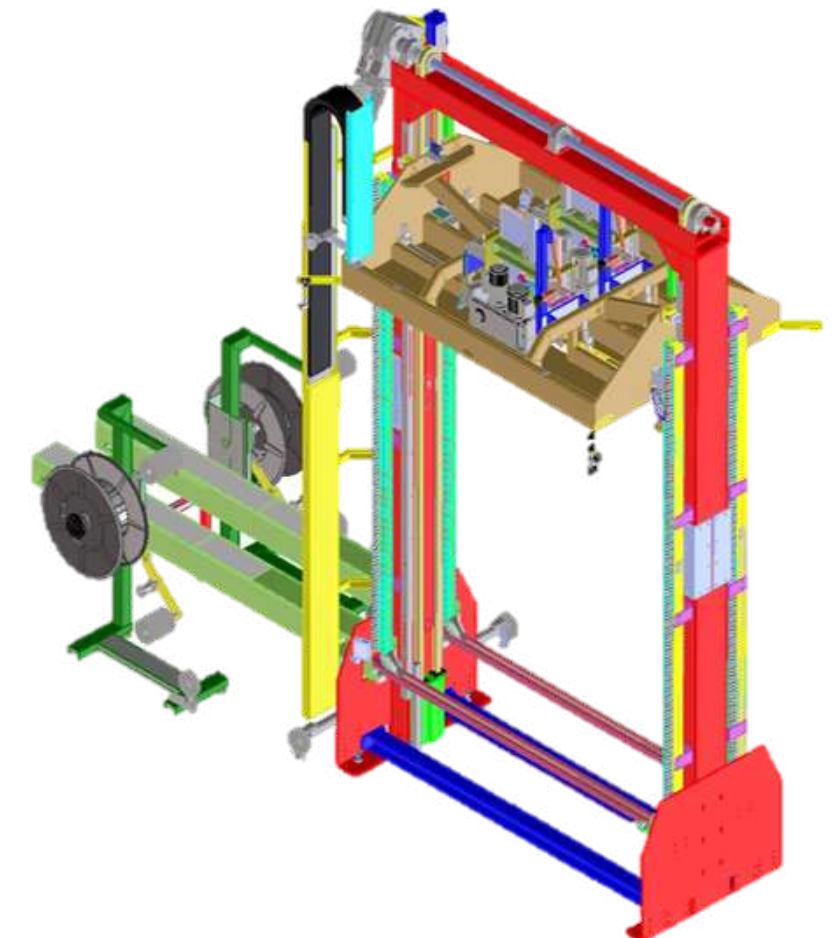

GENERAL SOLUTIONS

VKB/FLPS ENVASES VERSION

Compression	Side 500KG – 1100lb max Regulation by pressure value min – med. - high
Head	ITP16T – VK10 ITP80TH –K8000
Strap	PET/PP 9-16 mm 0.35 – 5/8 inches
Equipment	Two Columns Structures 1400mm min H to strap Double tension oscillation by cylinder

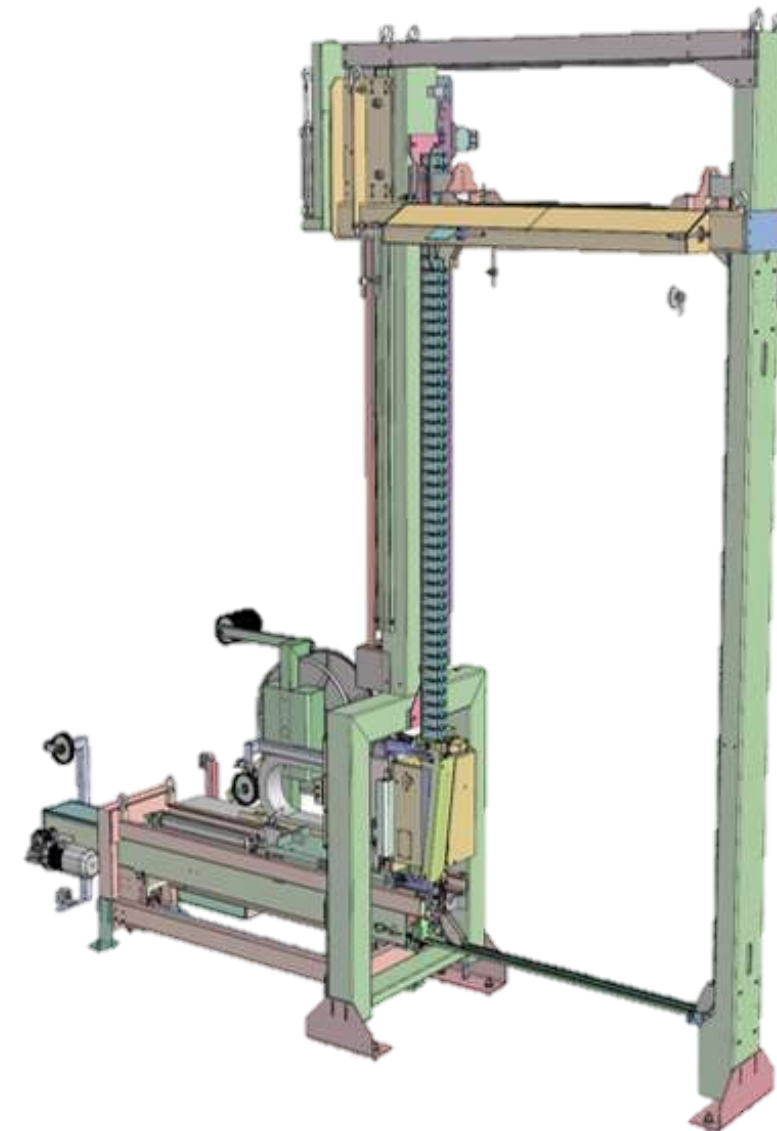

GENERAL SOLUTIONS

VKB/FLPS-2T

Compression	Side 500KG - 1100lb max Regulation by pressure value min - med. - high
Head	ITP16T - VK10 ITP80TH - K8000
Strap	PET/PP 9-16 mm 0.35 - 5/8 inches
Equipment	Small gates 1400mm min H to strap Double tension oscillation by cylinder

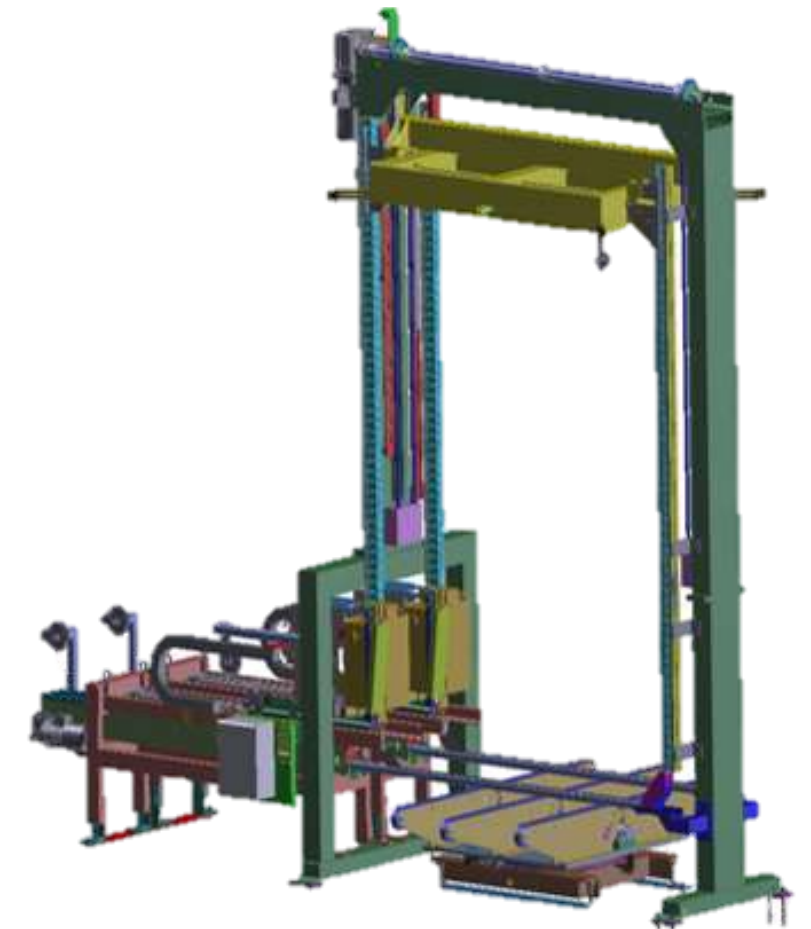

FEATURES

COMPRESSION SYSTEM

Standard setting by 3 different pressure values

Optional: Loading cell and inverter for more precise regulation done directly from HMI.



FEATURES

SAFETY PINS

Vertical bars with slots and a pneumatic pin

When the operator enters the area, the pin is active and blocks the plate in safety conditions.

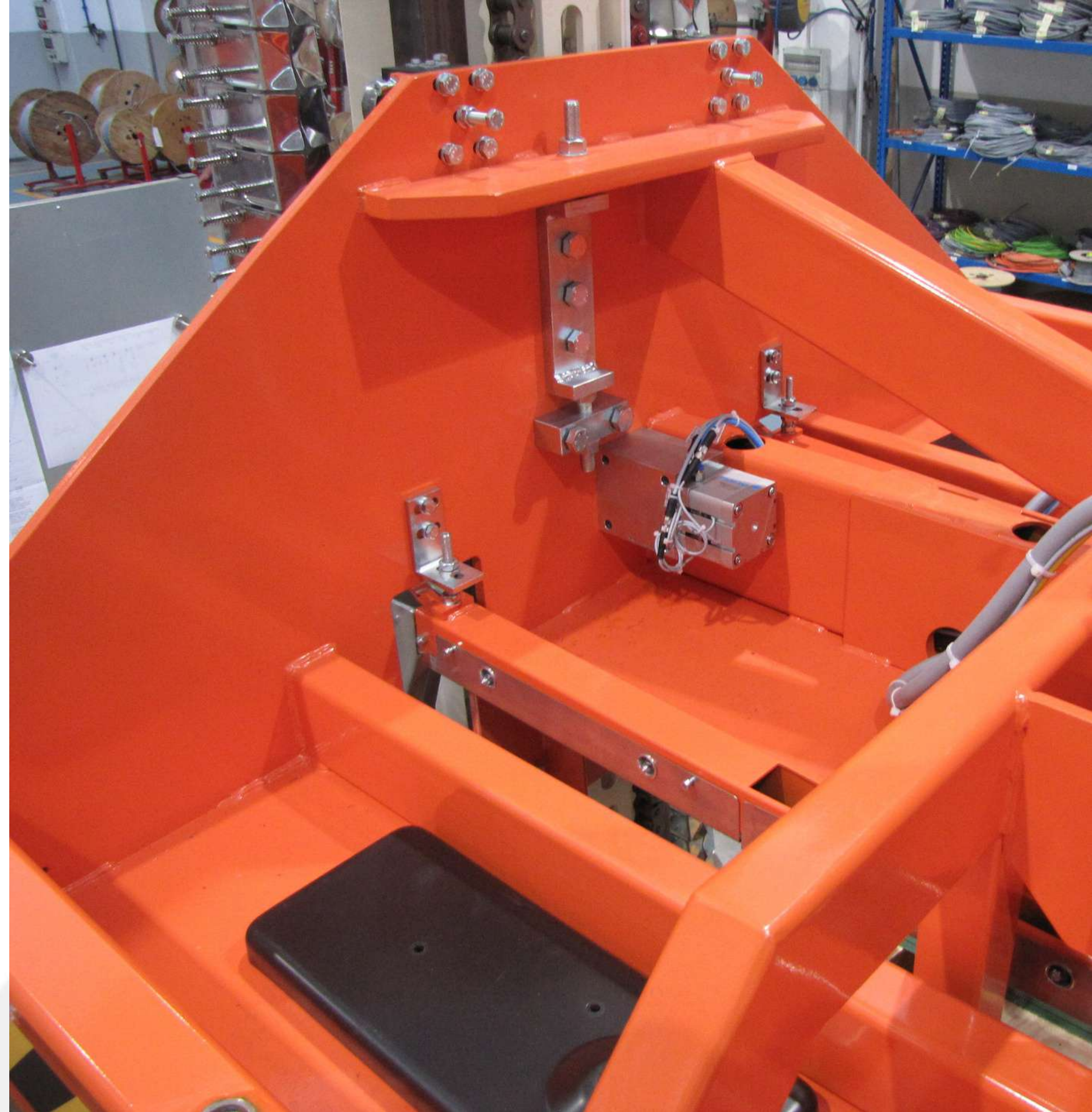

FEATURES

SMALL GATES ON VERTICAL CHANNELS

Self-positioning functions of the head tracking. When present in the machine. Improvement of the cycle time.

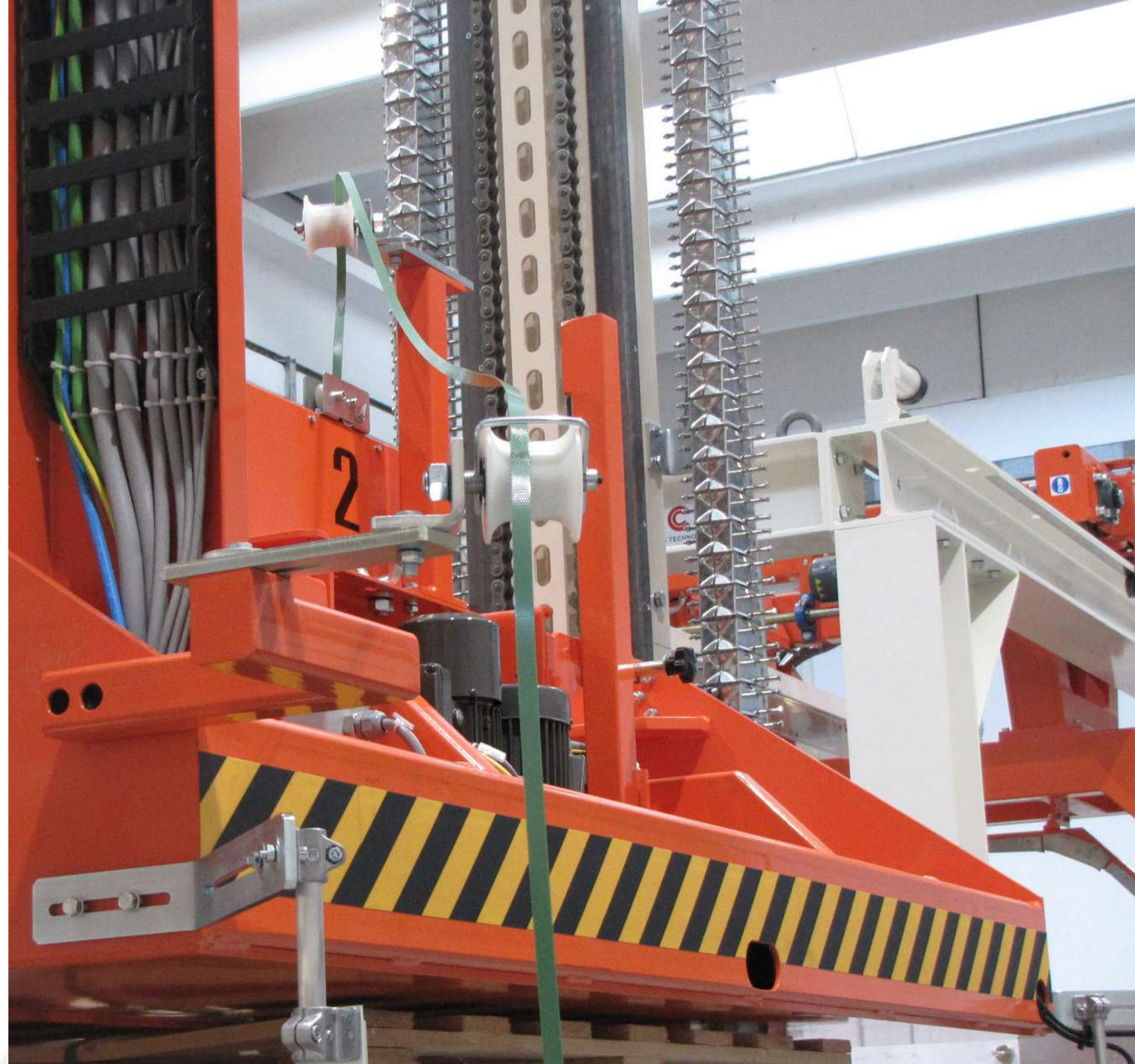

FEATURES

HMI

A/B PV Plus Colour Compact 6.5"



PLC

PLC A/B Compact Logix 5370 L2-1769



A close-up, slightly blurred view of a factory conveyor belt. The belt is filled with numerous clear glass bottles, arranged in neat rows. The bottles are moving from left to right. On the right side of the frame, a metal strapping mechanism is visible, with a strap being applied to the bottles. The background shows industrial machinery and a yellow safety rail, suggesting a factory or bottling plant environment. The overall lighting is somewhat dim, with a blueish tint.

CUSTOMIZED TO SUIT YOUR NEEDS

We work with customers to design a machine that will help them succeed. Our commitment to delivering what is needed in a strapping machine, whether it is a custom fit, custom solution or a standard machine, keeps businesses running smoothly and on time.



PARTS AND SERVICES

WE STAND BEHIND OUR PRODUCTS

PARTS

Itipack delivers a diligent and proactive approach to preventative maintenance while also providing trusted parts and service experience you can count on. Our primary focus is providing our clients with the best service, preventative maintenance, support and parts available.

SERVICES

It is important to have a diligent and proactive approach to preventative maintenance. Itipack works with you to implement the best program for your facility.

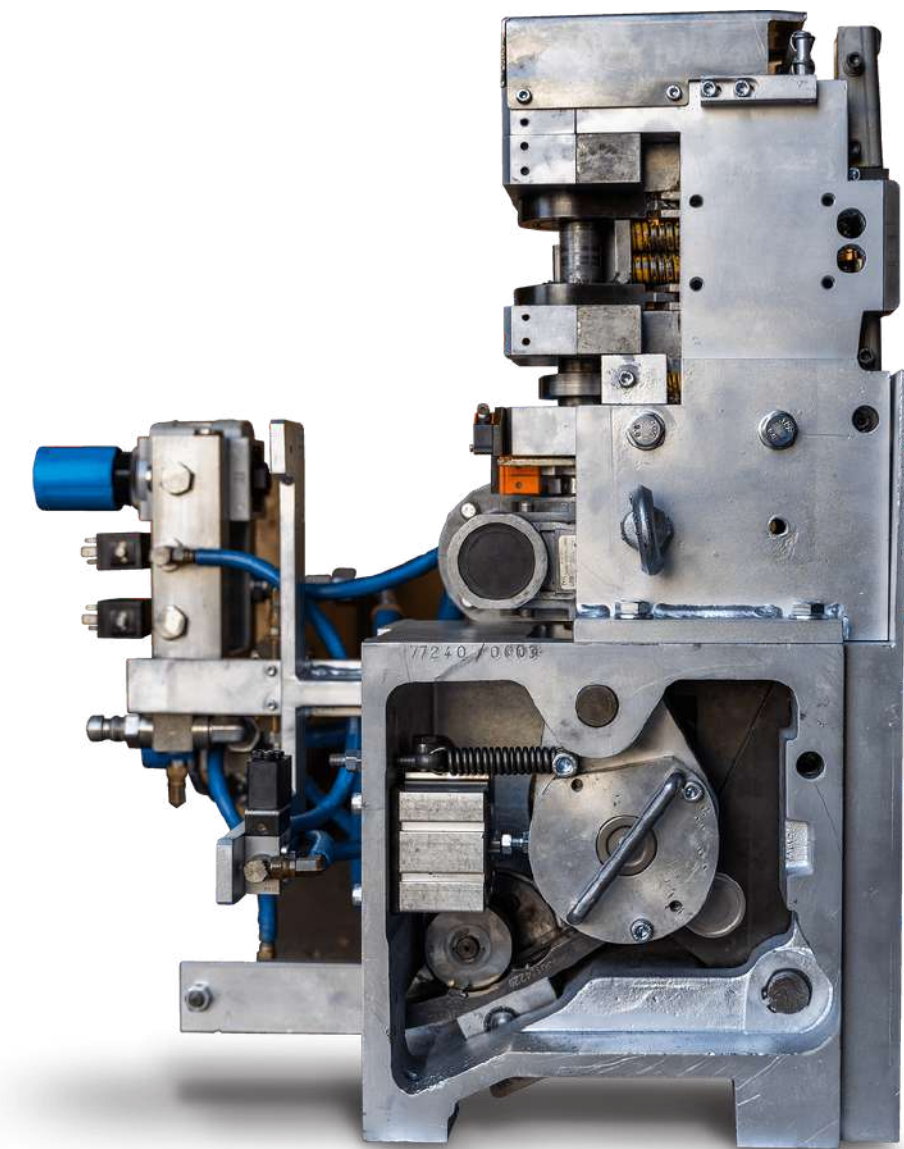

SERVICES

01

PREVENTATIVE MAINTENANCE PLAN

Itipack works very closely with clients to develop and implement a maintenance plan that best supports productivity and efficiency targets set for their Itipack strapping equipment.

02

STRAPPING HEAD REBUILD PROGRAM

We offer a comprehensive rebuild service that includes completely disassembling your strapping head and thoroughly inspecting/cleaning all inner and outer head components ultrasonically.



SERVICES

03

STRAPPING HEAD TRAINING

We provide in-class and hands-on training focused on preventative maintenance, with an emphasis on scheduled service and responsible replacement of pre-determined wear-spares parts.





MAILING ADDRESS:

919 ZELCO DRIVE,
BURLINGTON ON
L7L 4Y2

TELEPHONE:

905-333-3695

SERVICE:

716-225-5870
SERVICE@ITIPACKSYSTEMS.COM

SALES:

905-220-0551
SALES@ITIPACKSYSTEMS.COM

PARTS:

905-333-3695 X 227
SPAREPARTS@ITIPACKSYSTEMS.COM



THANK YOU